

Save time!
**Improve
safety!**



Datasheet

Easy Gripper 2400-2T

IDEAL FOR OTR TIRE HANDLING FOR

- Underground Mines
- Small Open Pit Mines / Quarries
- Harbour Cranes
- Tire Service



AVAILABLE FOR

- Forklifts
- Loaders
- Truck Cranes



www.justeasytools.dk

TECHNICAL SPECIFICATIONS

Easy Gripper 2400-2T



Ideal for handling of tires and wheels with various features to improve safety and effectivity. Is available for mounting on forklifts, loaders or truck cranes.

Features

- Safe 3-point grip
- Camera system as standard
- Precise rotation 0-50°
- Tilt function 90°
- Quick shift system - between the Gripper and the forks
- Flat arms for narrow space between tires and fenders
- Telescopic arms for handling two tires or wide duals
- Customization on request

- (A): Cg Gripper = 800 mm (31,5")
- (B): Rear of load = 1000 mm (39,4")
- (C): Cg load = 1550 mm (59,1")

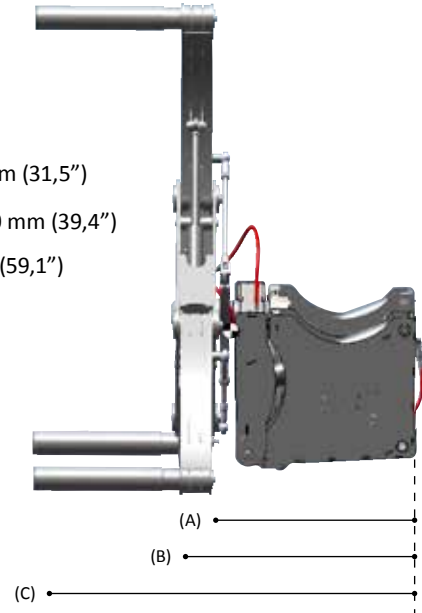

Accessories

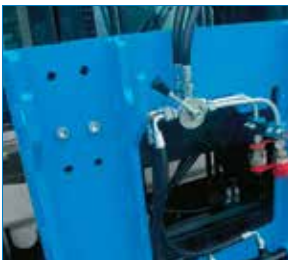

Quick Shift Module

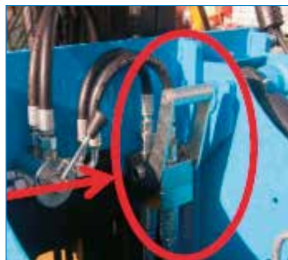

Hydraulic Quick Shift



Fork Module



Telescopic arms



Flat arm for narrow fenders

Technical Data

Weight (incl. QSM): 815 kg (1797 lbs)
Lifting capacity: 2000 kg (4410 lbs)

Tire diameter: 1.450 - 2.400 mm (57-94")
Diameter with special arms down to: 1.080 mm (43")
Standard arms: Ø115 x 650 mm (4,6 x 25,6")
Standard telescopic arms up to: 1.375 mm (54")

Technical Requirements

Lifting capacity: Individual calculation
Electrical: 12 (-24) Volt + 10 Amp

Hydraulic

1 double acting hydraulic connection
Pressure min-max: 150-250 bar (3626 psi)
Return pressure: max. 10 bar (145 psi)
Flow max: 50 l/min.